



F14 and 48000 SERIES

Service and Installation Manual

Please read this manual completely before attempting to install or operate this equipment! **Notify carrier of damage!** Inspect all components immediately. See page 3.



Hot Food Tables



**IMPORTANT INFORMATION
READ BEFORE USE
PLEASE SAVE THESE INSTRUCTIONS!**

Effective May 2003

CONTENTS SERIAL NUMBER LOCATION

SERIAL# LOCATION.....2
 RECEIVING & INSPECTING2
 SPECIFICATIONS3
 INSTALLATION
 F14EW & F14EI (electric)3
 48300 Series (electric)3
 F14GW (gas)5
 OPERATION
 F14EI & 48300 Series (electric)4
 F14EW (electric)4
 F14GW (gas)5
 MAINTENANCE5
 GAS BURNER ASSEMBLY: F14GW Series6
 DELFIELD FOOD WARMER (DFW) ASSEMBLIES
 with thermostatic controls7
 with infinite control8
 REPLACEMENT PARTS LISTS9
 WIRING DIAGRAMS
 F14EI & 48300 Series (electric)10
 F14EW (electric)11
 STANDARD WARRANTY 13-14
 AUTHORIZED PARTS DEPOTS.....(back cover)

The serial number on all 14 Series and 48000 Series hot food tables is printed on the tag located on the plate shelf. Always have the serial number of your unit available when calling for parts or service. A complete list of authorized Delfield parts depots is shown on the back cover of this manual.

©2003 The Delfield Company. All rights reserved. Reproduction without written permission is prohibited. "Delfield" is a registered trademark of The Delfield Company.

RECEIVING AND INSPECTING THE EQUIPMENT

Even though most equipment is shipped crated, care should be taken during unloading so the equipment is not damaged while being moved into the building.

1. Visually inspect the exterior of the package and skid or container. Any damage should be noted and reported to the delivering carrier immediately.
2. If damaged, open and inspect the contents with the carrier.
3. In the event that the exterior is not damaged, yet upon opening, there is concealed damage to the equipment notify the carrier. Notification should be made verbally as well as in written form.
4. Request an inspection by the shipping company of the damaged equipment. This should be done within 10 days from receipt of the equipment.

5. Check the lower portion of the unit to be sure legs or casters are not bent.
6. Also open the compressor compartment housing and visually inspect the refrigeration package. Be sure lines are secure and base is still intact.
7. Freight carriers can supply the necessary damage forms upon request.
8. Retain all crating material until an inspection has been made or waived.

Uncrating the Equipment

First cut and remove the banding from around the crate. Remove the front of the crate material, use of some tools will be required. If the unit is on legs remove the top of the crate and lift the unit off the skid. If the unit is on casters it can be "rolled" off the skid.



SPECIFICATIONS

MODEL NUMBER	NUMBER OF OPENINGS	AMPS 208/230	SHIP WEIGHT
Electric with individual wells — wet or dry operation			
F14EI232	2	10.0/11.0	216 lbs/98 kg
F14EI348	3	15.0/16.0	296 lbs/134 kg
F14EI460	4	20.0/22.0	376 lbs/170 kg
F14EI572	5	24.0/27.0	456 lbs/207 kg
F14EI688	6	29.0/32.0	536 lbs/243 kg

Electrical connections are 208/230 volt, 60 cycle, single phase.
Each opening measures 11.87" x 19.87" (30.2cm x 50.5cm).

Electric with single tank — wet operation only

F14EW232	2	21.0/24.0	316 lbs/143 kg
F14EW348	3	21.0/24.0	440 lbs/199 kg
F14EW460	4	21.0/24.0	500 lbs/227 kg
F14EW572	5	42.0/48.0	560 lbs/254 kg
F14EW688	6	42.0/48.0	660 lbs/299 kg

Electrical connections are 120/240 volt, or optional 120/208 volt.
(120 volt circuit is required for the low water cutoff.)

MODEL NUMBER	NUMBER OF OPENINGS*	NUMBER OF GAS BURNERS	BTU	SHIP WEIGHT
Gas with single tank — wet operation only				
F14GW232	2	1	20000	256 lbs/116 kg
F14GW348	3	1	20000	326 lbs/148 kg
F14GW460	4	1	20000	396 lbs/180 kg
F14GW572	5	2	40000	456 lbs/207 kg
F14GW688	6	2	40000	536 lbs/243 kg

*Each opening measures 11.87" x 19.87" (30.2cm x 50.5cm).

MODEL NUMBER	VOLTAGE	AMPS	SHIP WEIGHT
Electric with individual wells — wet or dry operation			
48334	120/208	17.0/11.0	179 lbs/81 kg
48348	208/230	15.0/16.0	252 lbs/114 kg
48362	208/230	20.0/22.0	326 lbs/148 kg
48376	208/230	24.0/27.0	400 lbs/181 kg

INSTALLATION: F14EI & F14EW SERIES (ELECTRIC)



Installation should only be done by personnel certified and licensed to install and maintain electrical appliances.

Location

Do not install the hot food table near any combustible objects or surfaces affected by heat or moisture.

Leveling

This unit must be level, both front and back and left to right, in order to maintain an equal water depth throughout the wells.

Plumbing

Hot water supply connection is provided 36" (91.4cm) above the floor, 3.12" (7.9cm) from the front left end at the rear of the unit. You must supply the required 1/2" NPT connection.

A waste connection is provided 25" (63.5cm) above the floor, 7.5" (19cm) from the right end. You must supply the required 1" NPT connection.

Electrical connection



Connections must be made in accordance with all applicable local codes and/or the National Electrical Code. Refer to the wiring diagrams on page 10.

INSTALLATION: 48300 SERIES (ELECTRIC)



Installation should only be done by personnel certified and licensed to install and maintain electrical appliances.

Location

Do not install the hot food table near any combustible objects or surfaces affected by heat or moisture.

Leveling

This unit must be level, both front and back and left to right, in order to maintain an equal water depth throughout the wells.

Plumbing

A waste connection is provided 26.5" (67.3cm) above the floor, 5.25" (13.3cm) from the right end. You must supply the required 1" NPT connection.

Electrical connection



Connections must be made in accordance with all applicable local codes and/or the National Electrical Code. Refer to the wiring diagrams on page 10.

OPERATION: F14EI & 48300 SERIES (ELECTRIC)

Before the unit is used the first time for serving, turn the temperature knob to “10” and heat the well for 20 to 30 minutes. Do not be alarmed if smoke appears; this preheat should burn off any residue or dust on the heating element.

When using thick sauces always operate the hot food well filled with water. This will provide a more uniform temperature for the sauce.



WEAR

Steam can cause serious burns. Always wear some type of protective covering on your hands and arms when removing lids or pans from the unit. Lift the lid or pan in a way that will direct escaping steam away from your face and body.



CAUTION

Never place food directly into the well. Always use pans.

Although these models may be operated either with or without water in the wells, wet operation is recommended.

Always place covers on pans when not serving to prevent food from drying out and to reduce your operating cost.

For most efficient operation when empty, keep covered insets in each well during preheating and when the well is not in use.

Do not put food down drain.

Wet operation



STEPS

- 1) Fill food well with two inches of water. For quicker pre-heating, use hot water to fill the well.
- 2) Turn the control to “HIGH” and pre-heat the warmer for 30 minutes.
- 3) After pre-heating, set the control to your desired serving temperature.

Dry operation



STEPS

- 1) Pre-heat the well on “HIGH” for approximately 15 minutes.
- 2) After pre-heating, set the control to your desired serving temperature.

Only 6” (15.2cm) deep insets should be used with a dry food well. When operated dry, the bottom of the food well will discolor. A mild abrasive cleaner is recommended to clean this discoloration.

Temperature

Water in wells	160°F to 180°F
Product in pans	140°F to 160°F

OPERATION: F14EW SERIES (ELECTRIC)

These units must be operated with water in the well. If operated dry, a low water safety switch will interrupt the electric supply to the heater to prevent heater failure. If the low water safety switch shuts off power, turn the control to the OFF position. If the water level is below the heating element, allow the well to cool completely, then refill with water. Reactivate the well by turning the control ON and resetting to the previous temperature. Continuous interruption of power due to a low water level may disable the heater permanently. Pouring water on a hot heating element will damage it.



CAUTION

Steam can cause serious burns. Always wear some type of protective covering on your hands and arms when removing lids or pans from the unit. Lift the lid or pan in a way that will direct escaping steam away from your face and body.



WEAR

Never place food directly into the well. Always use pans. Always place covers on pans when not serving to prevent food from drying out and to reduce your operating cost.

For most efficient operation, when empty, keep covered insets in each well during preheating and when the well is not in use.

Wet operation



STEPS

- 1) Fill food well with four inches of water (heater must be covered by water). For quicker pre-heating, use hot water to fill the well.
- 2) Set the control to your desired serving temperature.

Temperature

Water in wells	160°F to 180°F
Product in pans	140°F to 160°F

OPERATION: F14GW SERIES (GAS)

Gas connection



Only qualified and trained personnel should attempt to connect the gas. Wear a face shield during this procedure. Delfield is not responsible for injuries resulting from attempts connect the gas.

You must supply the necessary connection. A pressure regulated, 1/2" FPT. 20,000 BTU gas supply is required. A gas regulator is supplied installed.



Be sure the connection is made to maintain flow through the safety valve in the direction indicated by the arrow stamped on the valve case. See the gas burner assembly diagram on page 6.

After installation, check for leaks using a soap solution. Mix some water with dish or other soap and supply a small amount to the connection. If bubbles appear, the connection is not correct and must be reinstalled before operating the unit.



The pilot valve supplied is sized for use with natural gas. If LP gas is to be used, the pilot fitting must be changed from the standard .021" orifice to a .011" orifice. This orifice is supplied in a plastic pouch attached to the plate shelf.

Gas hot food tables must be operated with water in the well. Dry operation of this unit will cause distortion of the well or other serious damage.



Steam can cause serious burns. Always wear some type of protective covering on your hands and arms when removing lids or pans from the unit. Lift the lid or pan in a way that will direct escaping steam away from your face and body.



Never place food directly into the empty well, always use pans. Never operate burners without water in the well.

Always place covers on pans when not serving to prevent food from drying out and to reduce your operating cost.

For most efficient operation, when empty, keep covered insets in each well during preheating and when the well is not in use.

MAINTENANCE

The exterior can be cleaned using mild soap and warm water. If this is not sufficient try ammonia and water or a non-abrasive liquid cleaner. When cleaning the exterior, always rub with the grain of the stainless steel to avoid marring the finish. Do not use an abrasive cleaner because it will scratch the stainless steel. A stainless steel cleaner or polish may be used to eliminate water spotting and fingerprints and bring out the finish of the exterior. The interior of the food wells should be cleaned daily with a

Lighting the pilot



Only qualified and trained personnel should attempt to light the pilot. Wear a face shield during this procedure. Delfield is not responsible for injuries resulting from attempts to light the pilot.



- 1) Open the gas valve supplying fuel to the hot food table
- 2) Push down the reset button on the pilot valve, which is located behind the control panel, and light the pilot.
- 3) Continue to hold down the reset button for 30 to 45 seconds or until the pilot continues to burn when the button is released.
- 4) During the reset cycle, gas will flow to both the main and pilot burners.
- 5) If the pilot is not lit after steps 1-4 have been completed, close the gas valve and wait for at least 5 minutes before attempting to light the pilot again. This should allow any excess gas in the air around the unit to dissipate. If you are using LP gas, wait at least 15 minutes; any excess gas will "fall" to the floor and will require more time to dissipate.



Filling the well and pre-heating



- 1) With the drain cock closed, fill the well until approximately a four inch depth is obtained. More water may be required if shallow depth pans are used. Always pour water in the well before pre-heating. For quicker pre-heating use hot water to fill the well.
- 2) Turn the gas control knob 1/4 turn counterclockwise and wait for the water to preheat. Then set the control to your desired serving temperature.

Temperature

Water in wells	160°F to 180°F
Product in pans	140°F to 160°F

non-abrasive cleaner and non-abrasive pad. If necessary, a mild abrasive may be used on the interior of the pans only. Hard water stains and lime scaling may require a special cleaning product. Never use steel wool.



Do not use a hose or pressure washer on these units. The water will damage the electrical and gas components.

GAS BURNER ASSEMBLY: F14GW SERIES (SINGLE SHOWN)

NOTE: The same parts are used for the double burner assembly

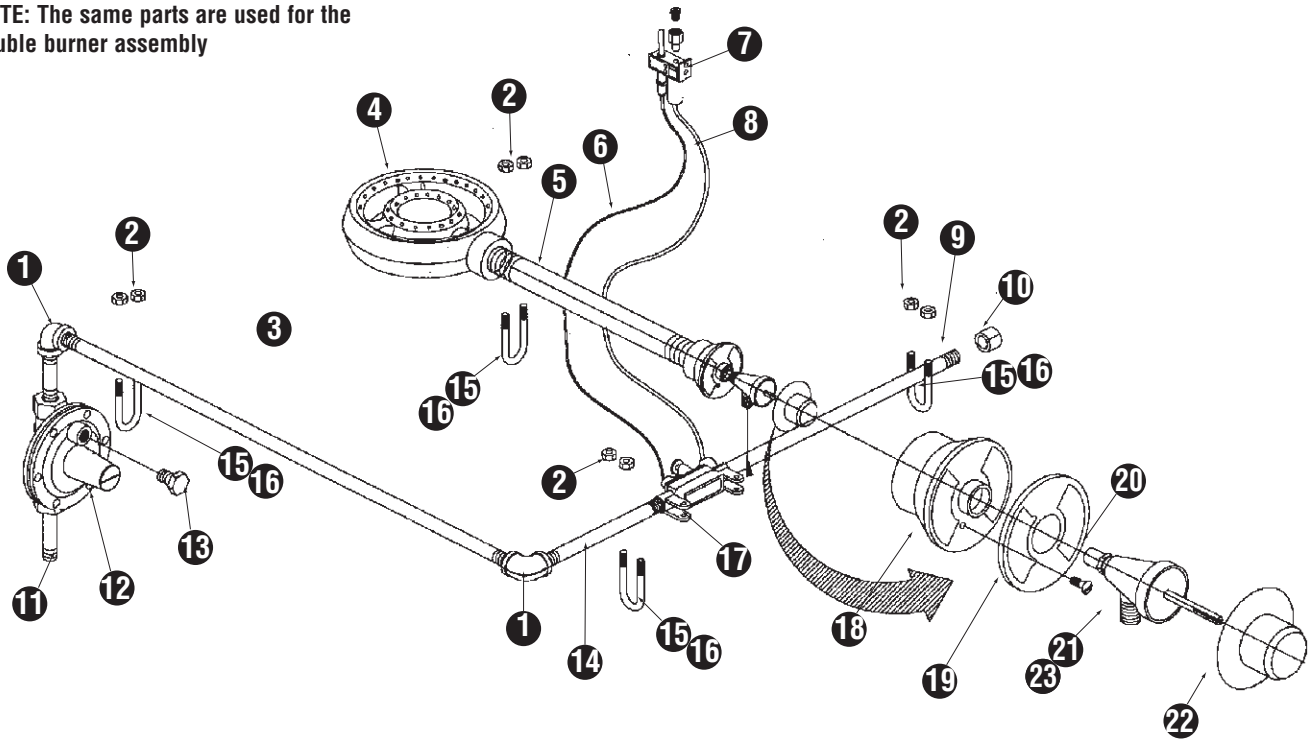

KEY	QTY	PART#	DESCRIPTION	KEY	QTY	PART#	DESCRIPTION
1	2	3547413	elbow 1/2" NPT	13	1	3234023	device, vent limiting, gas reg.
2	8	9321035	nut, 1/4-20	14	1	3547406	nipple, 1/2 x 6.5"
3	1	3547411	manifold nipple, 23"	15	4	9321157	u-bolt, 1/4 - 20
4	1	3234205A	gas burner assy	16	8	9321059	washer, 1/4
5	1	3547409	nipple, 3/4 x 12	17	1	3234343	valve, safety
6	1	3234341	thermocouple	18	1	3234205B	chamber, air mixing
7	1	3234342	pilot assembly	19	1	3234205C	plate, air mixing
8	20	3547329	tubing, copper, 1/4 O.D. x .028	20	1	3547593	fitting, inlet, burner (natural)
9	1	3547407	pipe, manifold, valve, 12"	21	1	3234205D	cock, front handle
10	1	3547408	cap, 1/2 NPT	22	1	3234205E	handle, valve
11	2	3547234	nipple, 1/2" x 2"	23	1	3547591	fitting, inlet burner (LP)
12	1	3234022	regulator, natural gas	24	1	3547412	nipple, manifold 31.25" dbl bnr only

DELFIELD FOOD WELL (DFW) ASSEMBLY: WITH THERMOSTATIC CONTROL

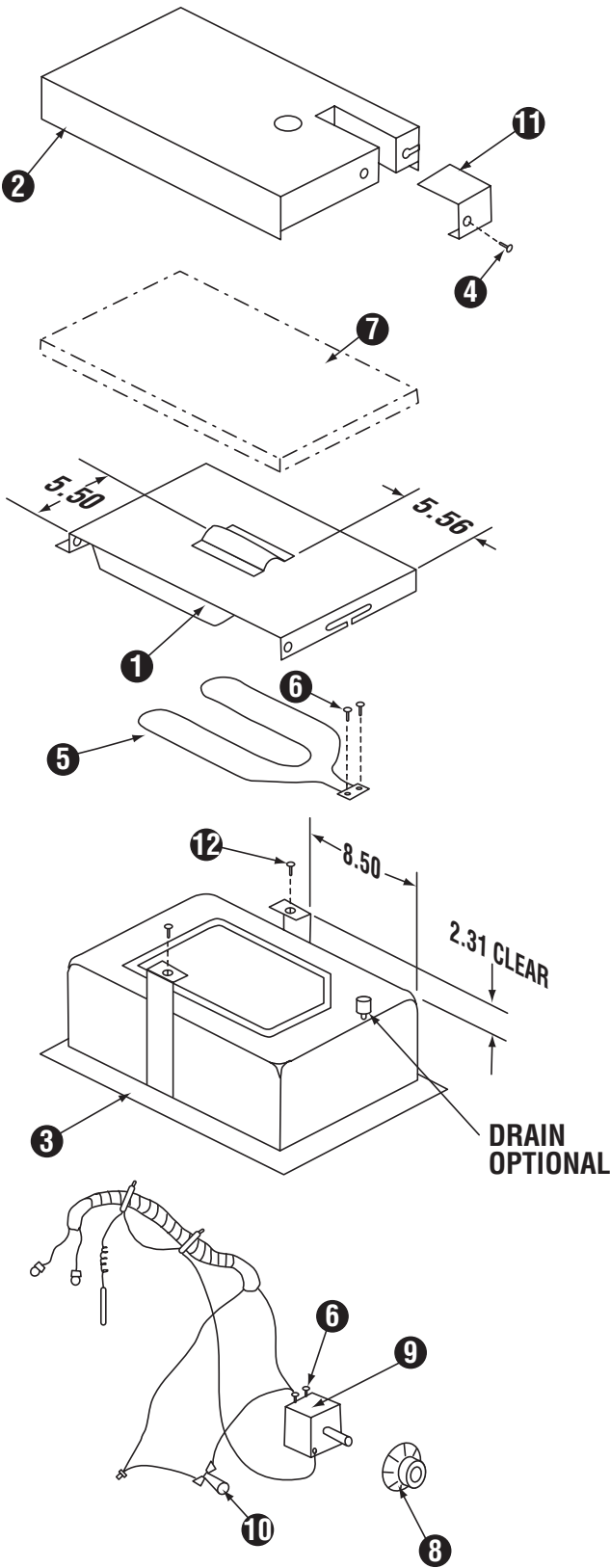

THERMOSTATIC CONTROL

KEY	PART NAME	DELFIELD PART #
	Complete assembly, 115V, thermostat w/drain	XMK00100
	Complete assembly, 115V, thermostat w/o drain	XMK00101
	Complete assembly, 208V, thermostat w/drain	XMK00102
	Complete assembly, 208V, thermostat w/o drain	XMK00103
1	Deflector plate	GMK00061
2	Bottom cover	GMK00062
3	Food well, with drain	016-0014
	Food well, without drain	016-0015
4	Screw	932-1353
5	Element, 115V	219-4006
	Element, 208V	219-4007
6	Screws (6)	932-1379
7	Insulation	343-4663
8	Thermostat control knob	323-4556
9	Thermostat, 200-550F	219-4012
10	Pilot light, red, 115V	219-4190
	Pilot light, amber, 230V	219-4095
11	Drain cover	GMK00063
12	Screws (2)	932-1353

NOTE: If you need four or more component parts, you must buy a complete assembly.

DELFIELD FOOD WELL (DFW) ASSEMBLY: WITH INFINITE CONTROL

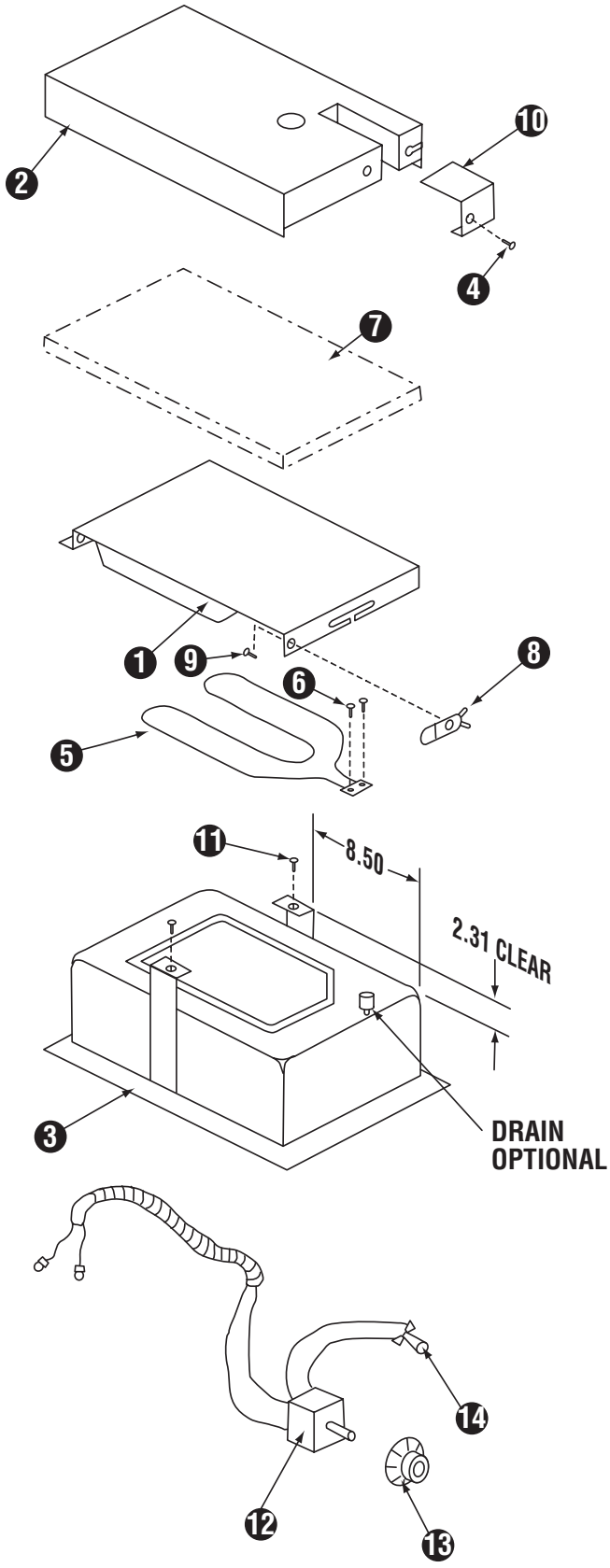

INFINITE CONTROL

KEY	PART NAME	DELFIELD PART #
	Complete assembly, 115V, infinite w/drain	XMK00104
	Complete assembly, 115V, infinite w/o drain	XMK00105
	Complete assembly, 208V, infinite w/drain	XMK00068
	Complete assembly, 208V, infinite w/o drain	XMK00106
1	Deflector plate	GMK00061
2	Bottom cover	GMK00062
3	Food well, with drain	016-0014
	Food well, without drain	016-0015
4	Screw	932-1353
5	Element, 115V	219-4006
	Element, 208V	219-4007
6	Screws (2)	932-1379
7	Insulation	343-4663
8	Thermostat non-adjustable	219-4335
9	Screw	932-1007
10	Drain cover	GMK00063
11	Screws (2)	932-1007
12	Infinite control, 120V	219-4107
	Infinite control, 230V	219-4110
13	Infinite control knob	323-4557
14	Pilot light, red, 115V	219-4190
	Pilot light, amber, 230V	219-4095

NOTE: If you need four or more component parts, you must buy a complete assembly.



MISCELLANEOUS PARTS LISTS

F14EI Series (electric)

PART NAME	DELFIELD PART #
Faucet	323-4075
Food well assembly	see pgs. 7-8
Gate valve 1/2"	354-7486
Legs, 6" w/mounting plate	323-4645

F14EW Series (electric)

PART NAME	DELFIELD PART #
Brass drain	323-4065
Contactora, relay 30 amp, 120V	219-4185
Faucet	323-4075
Float switch	219-4156
Gate valve, 1"	354-7487
Knob, thermostatic control	323-4556
Legs, 6" w/mounting plate	323-4645
Light, pilot, 250V, amber	219-4095
Relay, socket, KU12	219-4133
Relay, 8501, KU12	219-4132
Immersion heater 5KW, 240V, 12.0 amps 3-phase	219-3972
Immersion heater 5KW, 208V, 24.0 amps, 1-phase	219-3973
Immersion heater 5KW, 240V 20.8 amps, 1-phase	219-3974
Immersion heater 5KW, 208V, 13.9 amps, 3-phase	219-3975
Thermostat	219-4202
Gas burner assembly	see page 6

F14GW Series (gas)

PART NAME	DELFIELD PART #
Faucet	323-4075
Gate valve 1"	354-7487
Legs, 6" w/mounting plate	323-4645

48300 Series (electric)

PART NAME	DELFIELD PART #
Bullet feet (4)	323-4224
Casters	323-4406
Leg	323-4645
Cutting board pin cap	170-1000
Cutting board pin screw	932-1060
Brass cutting board hinge pin	323-4360
Food well assembly	see pgs. 7-8
Gate valve, 1/2"	354-7486
Polyethylene board, model 48334	130-1396
Polyethylene board, model 48348	130-1397
Polyethylene board, model 48362	130-1398
Polyethylene board, model 48376	130-1399

WIRING DIAGRAMS: F14EI AND 48300 SERIES

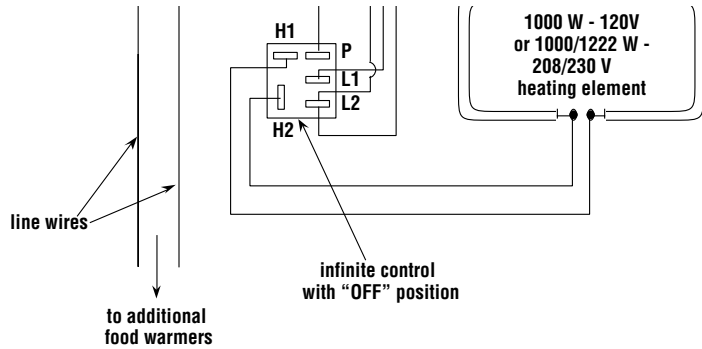

120 or 208-240V SINGLE PHASE MODELS

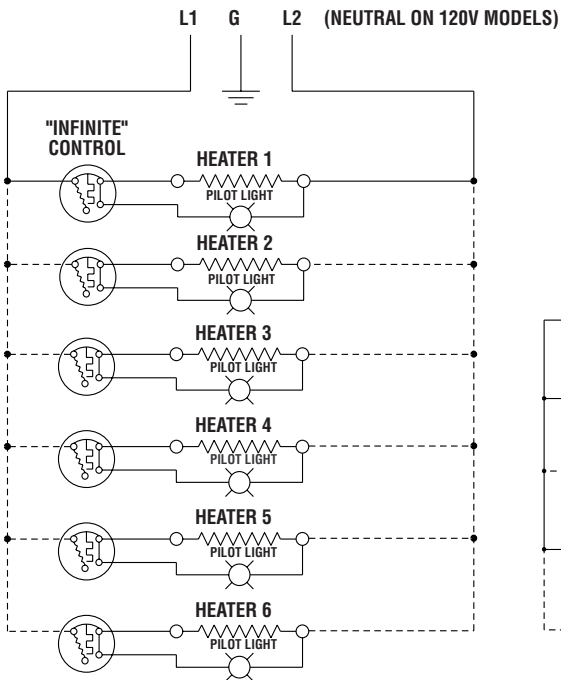

208-240V 3 PHASE MODELS

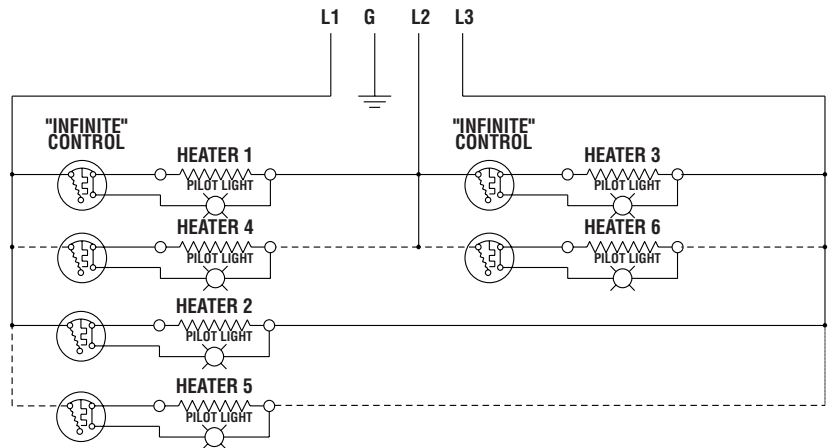

WIRING DIAGRAMS: F14EW SERIES

120-208 OR 120-240 VOLT SINGLE PHASE SUPPLY

Single Phase

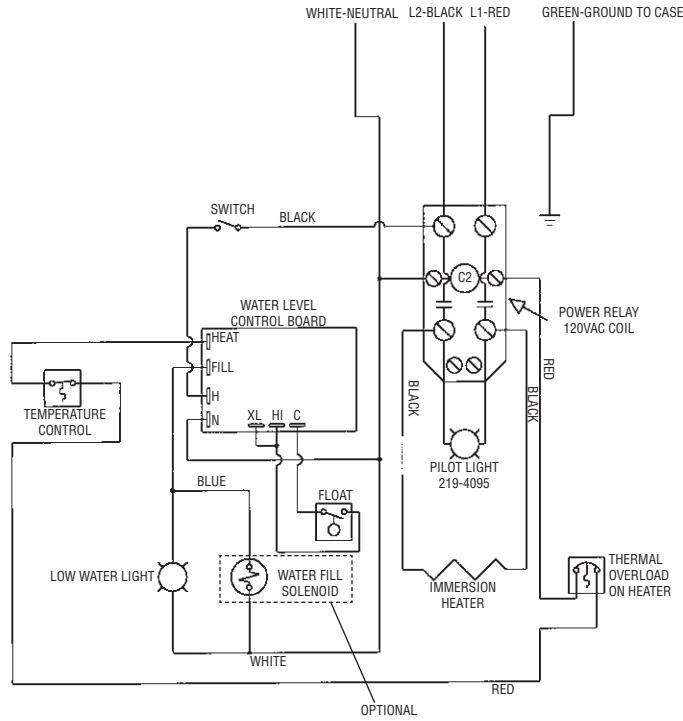

120-208 OR 120-240 VOLT THREE PHASE SUPPLY

Three Phase

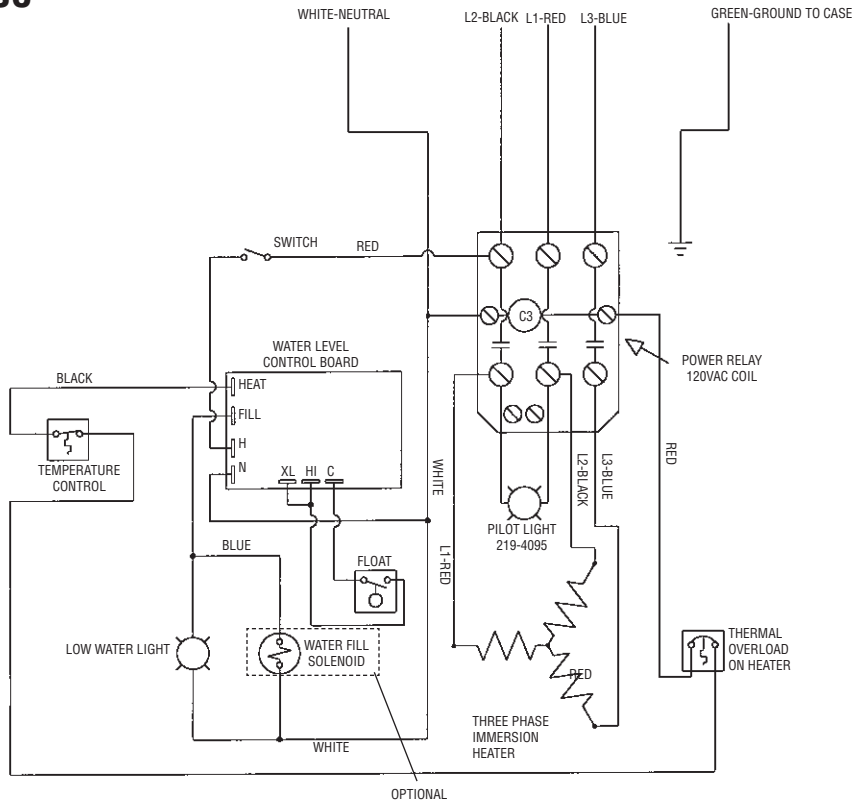

STANDARD LABOR GUIDELINES TO REPAIR OR REPLACE PARTS ON DELFIELD EQUIPMENT

Advice and recommendations given by Delfield Service Technicians do not constitute or guarantee any special coverage.

- A maximum of 1-hour is allowed to **diagnose a defective component**.
- A maximum of 1-hour is allowed for **retrieval of parts** not in stock.
- A maximum **travel distance** of 100 miles round trip and 2-hours will be reimbursed.
- Overtime, installation/start-up, normal control adjustments, general maintenance, glass breakage, freight damage, and/or correcting and end-user installation error will not be reimbursed under warranty unless pre-approved with a **Service Work Authorization** from Delfield. You must submit the number with the service claim.

LABOR OF 1-HOUR IS ALLOWED TO REPLACE:

- Thermostat
- Infinite Switch
- Door Jamb Switch
- Solenoid Coil
- Hi-limit/Thermal Protector Switch
- Fan Delay/Defrost Termination Switch
- Compressor Start Components and Overload Protector
- Defrost Timer
- Thermometer
- Gear Box
- Contactor/Relay
- Transformer
- Evaporator/Condenser Fan Motor and Blade
- Circulating Fan Motor and Blade
- Microprocessor Control
- Water Level Sensor/Probe
- Door Hinges, Locks, and Gaskets
- Condensate Element
- Springs/Lowerator

LABOR OF 2 HOURS TO REPLACE:

- Drawer Tracks/Cartridges
- Pressure Control
- Solenoid Valve
- Defrost Element
- Heating Element
- Locate/Repair Leak

LABOR OF 3 HOURS TO REPLACE:

- EPR or CPR Valve
- Expansion Valve
- Condenser or Evaporator Coil

LABOR OF 4 HOURS TO REPLACE

- Compressor

This includes recovery of refrigerant and leak check.

\$35.00 maximum reimbursement for refrigerant recovery (includes recovery machine, pump, torch, oil, flux, minor fittings, solder, brazing rod, nitrogen, or similar fees.)

REFRIGERANTS

- R22 A maximum of \$4.00/lb. or 25¢/oz. will be reimbursed.
- R134A A maximum of \$5.00/lb. or 31¢/oz. will be reimbursed.
- R404A A maximum of \$12.00/lb. or 75¢/oz. will be reimbursed.

STANDARD ONE YEAR WARRANTY (One year parts, 90 days labor.)

The Delfield Company ("Delfield") warrants to the Original Purchaser of the Delfield product (herein called the "Unit") that such Unit, and all parts thereof, will be free from defects in material and workmanship under normal use and service for a period of one (1) year from the date of shipment of the Unit to the Original Purchaser **or, if the Original Purchaser returns the warranty card completely filled out including the date of installation within thirty (30) days of receipt of the Unit, one (1) year from the date of installation.** During this one year warranty period, Delfield will repair or replace any defective part or portion thereof returned to Delfield by the Original Purchaser which Delfield determines was defective due to faulty material or workmanship. The Original purchaser will pay all labor, crating, freight and related costs incurred in the removal of the Unit of defective component and shipment to Delfield, except that during a period of either ninety (90) days from the date of shipment of the Unit to the Original Purchaser or, if the Original Purchaser returns the warranty card completely filled out including the date of installation within thirty (30) days of receipt of the Unit, ninety (90) days from the date of installation Delfield will pay all related labor costs. Delfield will pay the return costs if the Unit or part thereof was defective.

The term "Original Purchaser" as used herein means that person, firm, association, or corporation for whom the Unit was originally installed.

This warranty does not apply to any Unit or part thereof that has been subjected to misuse, neglect, alteration, or accident, such as accidental damage to the exterior finish, operated contrary to the recommendations specified by Delfield; or repaired or altered by anyone other than Delfield in any way so as to, in Delfield's sole judgement, affect its quality or efficiency. This warranty does not apply to any Unit that has been moved from the location where it was originally installed. This warranty also does not cover the refrigerator drier or the light bulbs used in the Unit. **The warranty is subject to the user's normal maintenance and care responsibility as set forth in the Service and Installation Manual, such as cleaning the condenser coil, and is in lieu of all other obligations of Delfield. Delfield neither assumes, nor authorizes any other person to assume for Delfield, any other liability in connection with Delfield's products.**

Removal or defacement of the original Serial Number or Model Number from any Unit shall be deemed to release Delfield from all obligations hereunder or any other obligations, express or implied.

Parts furnished by suppliers to Delfield are guaranteed by Delfield only to the extent of the original manufacturer's express warranty to Delfield. Failure of the Original Purchaser to receive such manufacturer's express warranty to Delfield. Failure of the Original Purchaser to receive such manufacturer's warranty shall in no way create any warranty, expressed or implied, or any other obligation or liability on Delfield's part in respect thereof.

IF THE CUSTOMER IS USING A PART THAT RESULTS IN A VOIDED WARRANTY AND A DELFIELD AUTHORIZED REPRESENTATIVE TRAVELS TO THE INSTALLATION ADDRESS TO PERFORM WARRANTY SERVICE, THE SERVICE REPRESENTATIVE WILL ADVISE CUSTOMER THE WARRANTY IS VOID. SUCH SERVICE CALLS WILL BE BILLED TO CUSTOMER AT THE AUTHORIZED SERVICE CENTER'S THEN APPLICABLE TIME AND MATERIALS RATES. CONSIDER: CUSTOMER MAY INITIATE A SERVICE AGREEMENT WITHOUT PARTS COVERAGE.

If shipment of a replacement part is requested prior to the arrival in the Delfield factory of the part claimed to be defective, the Original Purchaser must accept delivery of the replacement part of a C.O.D. basis, with credit

being issued after the part has been received and inspected at Delfield's plant and determined by Delfield to be within this warranty.

Under no condition does this warranty give the Original Purchaser the right to replace the defective Unit with a complete Unit of the same manufacturer or of another make. Unless authorized by Delfield in writing, this warranty does not permit the replacement of any part, including the motor-compressor, to be made with the part of another make or manufacturer.

No claims can be made under this warranty for spoilage of any products for any reason, including system failure.

The installation contractor shall be responsible for building access, entrance and field conditions to insure sufficient clearance to allow any hood(s), vent(s), or Unit(s) if necessary, to be brought into the building. Delfield will not be responsible for structural changes or damages incurred during installation of the Unit or any exhaust system.

Delfield shall not be liable in any manner for any default or delay in performance hereunder caused by or resulting from any contingency beyond Delfield's control, including, but not limited to, war, governmental restrictions or restraints, strike, lockouts, injunctions, fire, flood, acts of nature, short or reduced supply of raw materials, or discontinuance of the parts by the original part manufacturer.

Except as provided in any Additional Four Year Protection Plan, if applicable, and the Service Labor Contract, if applicable, the foregoing is exclusive and in lieu of all other warranties, whether written or oral, express or implied. This warranty supersedes and excludes any prior oral or written representations or warranties. Delfield expressly disclaims any implied warranties of merchantability, fitness for a particular purpose of compliance with any law, treaty, rule or regulation relating to the discharge of substances into the environment. The sole and exclusive remedies of any person relating to the Unit, and the full liability of Delfield for any breach of this warranty, will be as provided in this warranty.

Other than this Delfield Standard One Year Limited Warranty, any applicable Delfield Standard Four Year Protection Plan or applicable Delfield Service Labor Contract, the Original Purchaser agrees and acknowledges that no other warranties are offered or provided in connection with or for the unit or any other part thereof.

In no event will Delfield be liable for special, incidental or consequential damages, or for damages in the nature of penalties.

IF DURING THE WARRANTY PERIOD, CUSTOMER USES A PART FOR THIS DELFIELD EQUIPMENT OTHER THAN AN UNMODIFIED NEW OR RECYCLED PART PURCHASED DIRECTLY FROM DELFIELD OR ANY OF ITS AUTHORIZED SERVICE CENTERS AND/OR THE PART BEING USED IS MODIFIED FROM ITS ORIGINAL CONFIGURATION, THIS WARRANTY WILL BE VOID. FURTHER, DELFIELD AND ITS AFFILIATES WILL NOT BE LIABLE FOR ANY CLAIMS DAMAGES OR EXPENSES INCURRED BY THE CUSTOMER WHICH ARISE DIRECTLY OR INDIRECTLY, IN WHOLE OR IN PART, DUE TO THE INSTALLATION OF ANY MODIFIED PART AND/OR PART RECEIVED FROM AN UNAUTHORIZED SERVICE CENTER. If the warranty becomes void, Customer may purchase from Delfield, if available, a Service Agreement or service at the then current time and materials rate.

For more information on Delfield warranty's log on and check out the service section of our web site at www.delfield.com.



ADDITIONAL FOUR YEAR PROTECTION PLAN (for Motor-Compressor only)

Delfield Model#	Serial #	Installation Date

In addition to the Standard One Year Warranty on the Motor-Compressor contained in the above listed Delfield product (the "Unit"), The Delfield Company ("Delfield") also agrees to repair, or exchange with similar or interchangeable parts in design and capacity at Delfield's option, the defective Motor-Compressor contained in the Unit (the "Motor-Compressor"), or any part thereof, for the Original Purchaser only, at any time during the four (4) years following the initial one (1) year period commencing on the date of installation for the Original Purchaser. **Failure of the Original Purchaser to register the registration card containing the Original Purchasers name, address, date of installation, model number and serial number of the Unit containing the Motor-Compressor within 30 days from the date of installation shall void this warranty.** This additional warranty is only available if the Motor-Compressor is inoperative due to defects in material or factory workmanship, as determined by Delfield in its sole judgement and discretion. The Original Purchaser shall be responsible for returning the defective Motor-Compressor to Delfield prepaid, F.O.B. at the address shown on the back cover of this manual.

The term "Original Purchaser" as used herein means that person, firm, association, or corporation for whom the Unit was originally installed.

The term "Motor-Compressor" as used herein does not include unit base, air or water cooled condenser, receiver, electrical accessories such as relay, capacitors, refrigerant controls, or condenser fan/motor assembly. This warranty does not cover labor charges incidental to the replacement of parts. This warranty further does not include any equipment to which said condensing unit is connected, such as cooling coils, temperature controls or refrigerant metering devices. This warranty shall be void if the Motor-Compressor, in Delfield's sole judgement, has been subjected to misuse, neglect, alteration or accident, operated contrary to the recommendations specified by the Unit manufacturer, repaired or altered by anyone other than Delfield in any way so as, in Delfield's sole judgment, to affect its quality or efficiency or if the serial number has been altered, defaced or removed. This Warranty does not apply to a Motor-Compressor in any Unit that has been moved from the location where it was originally installed. The addition of methyl chloride to the condensing unit or refrigeration system shall void this warranty.

General Conditions

Delfield shall not be liable in any manner for any default or delay in performance hereunder caused by or resulting from any contingency beyond Delfield's control, including, but not limited to, war, governmental restrictions or restraints, strike, lockouts, injunctions, fire, flood, acts of nature, short or reduced supply of raw materials, or discontinuance of any part or the Motor-Compressor by the unit manufacturer.

Replacement of a defective Motor-Compressor is limited to one (1) Motor-Compressor by us during the four (4) year period. Delfield shall replace the Motor-Compressor at no charge.

This warranty does not give the Original Purchaser of the Motor-Compressor the right to purchase a complete replacement Motor-Compressor of the same make or of another make. It further does not permit the replacement to be made with a Motor-Compressor of another kind unless authorized by Delfield. In the event Delfield authorizes the Original Purchaser to purchase a replacement Motor-Compressor locally, only the wholesale cost of the Motor-Compressor is refundable.

Expressly excluded from this warranty are damages resulting from spoilage of goods.

Except as provided in any applicable Standard One Year Limited Warranty or applicable Service Labor Contract, the foregoing is exclusive and in lieu of all other warranties, whether written or oral, express or implied. This Warranty supersedes and excludes any prior oral or written representations or warranties. Delfield expressly disclaims any implied warranties of merchantability, fitness for a particular purpose or compliance with any law, treaty, rule or regulation relating to the Motor-Compressor, and the full liability of Delfield for any breach of this warranty, will be as provided in this warranty.

Other than any applicable Delfield Standard One year Limited Warranty, this Delfield Additional Four Year Protection Plan and any applicable Delfield Service Labor Contract, the Original Purchaser agrees and acknowledges that no other warranties are offered or provided in connection with or for the Motor-Compressor or any part thereof.

In no event will Delfield be liable for special, incidental or consequential damages, or for damages in the nature of penalties.



NOTES:

AUTHORIZED PARTS DEPOTS

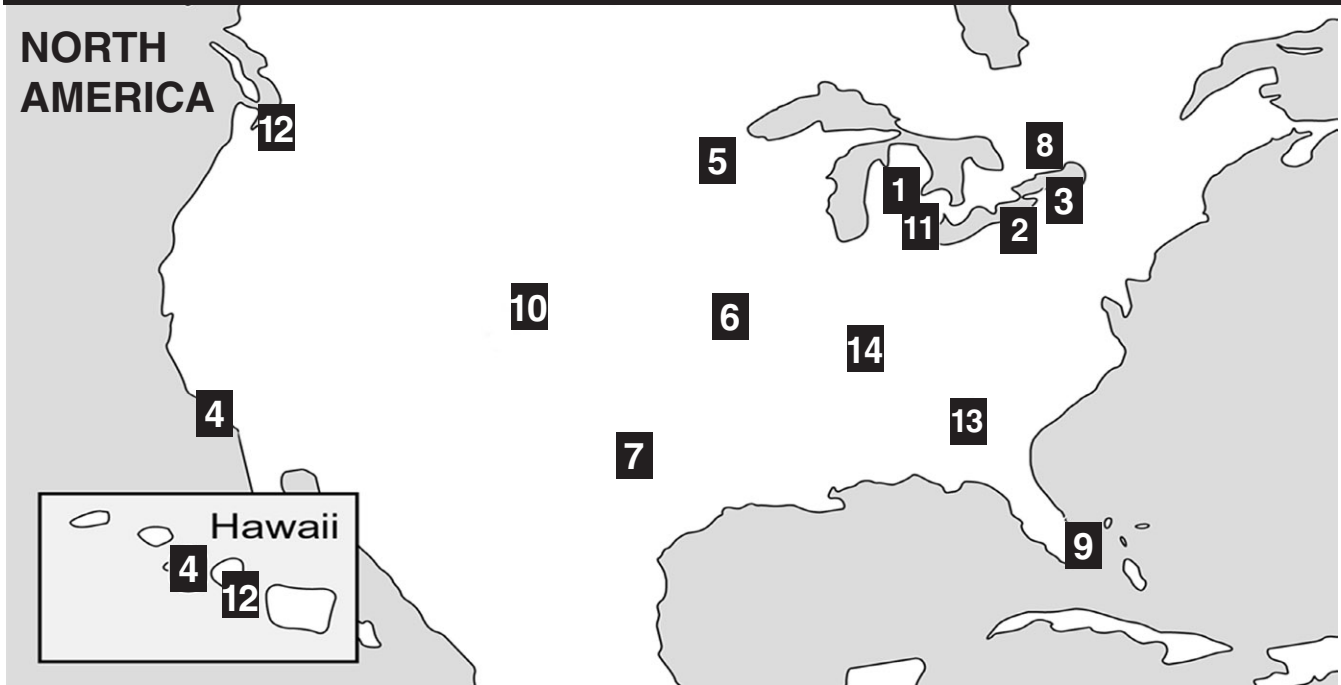

<p>1) The Delfield Company</p> <p>980 South Isabella Road Mt. Pleasant, MI 48858 800.733.8829 989.773.7981 989.773.3210 FAX custom parts direct from Delfield</p>	<p>2) A.I.S. Commercial Parts & Service</p> <p>1816 West 26th Street Erie, PA 16508-1149 800.332.3732 814.456.3732 814.452.4843 FAX serves: MD, NJ, OH, PA, VA, WV</p>	<p>3) Appliance Installation Service</p> <p>1336 Main Street Buffalo, NY 14209 800.722.1252 716.884.7425 716.884.0410 FAX serves: CT, DC, DE, MA, MD, ME, NH, NJ, NY, PA, RI, VA, VT, WV</p>	<p>4) Pacific Coast Parts</p> <p>15024 Staff Court Gardena, CA 90248 1.800.531.1111 1.800.782.5747 Email: orders@pacparts.com www.pacparts.com serves: AZ, CA, HI, NV, OR</p>
<p>5) Contract Ice</p> <p>14450 Ewing Ave S. #100 Burnsville, MN 55306 800.422.2823 952.894.4427 952.894.2164 FAX serves: IA, MN, MT, ND, SD, WI</p>	<p>6) E.M.C.O. Sales & Distributors</p> <p>3909 St. Timothy Lane St. Ann, MO 63074 800.972.7670 314.427.7477 314.427.8190 FAX serves: AR, IA, IL, KS, KY, MO, NE, OK, TX, NM, LA</p>	<p>7) Stove Parts Supply/GCS Service</p> <p>2120 Solona St. PO Box 14009 Fort Worth, TX 76117-0009 1.800.433.1804 toll free 1.800.272.7358 fax serves: AR, LA, NM, OK, TX</p>	<p>8) Garland Group</p> <p>1177 Kamato Road Mississauga, Ontario L4W1X4 800.427.6668 800.361.7745 FAX serves: Canada</p>
<p>9) Global Parts and Supplies</p> <p>2920 N.W. 109th Avenue Miami, FL 33172 305.994.9994 305.994.9992 FAX International parts depot</p>	<p>10) Hawkins Commercial Appl. Serv.</p> <p>3000 S. Wyandot Englewood, CO 80110 (800) 624-2117 (303) 7618861 FAX serves: AZ, CO, KS, NE, NM, OK, UT, WY</p>	<p>11) MicroDine, Inc.</p> <p>44792 Helm Plymouth, MI 48170 888.828.4454 734.451.2043 734.451.3215 FAX serves: MI, IN, WI, OH</p>	<p>12) Performance Refrigeration Parts</p> <p>9923 S.W. 178th St. Vashon, WA 98070 888.872.2465 206-463-1772 206.463.4431 FAX serves: AK, HI, ID, MT, OR, WA</p>
<p>13) Southeastern Restaurant Services</p> <p>2200 Norcross Parkway, Suite 210 Atlanta, GA 30071 800.235.6516 770.446.6177 770.446.3157 FAX serves: FL, GA, MS, NC, SC, VA</p>	<p>14) T.M.A.</p> <p>2916 Sidco Drive Nashville, TN 37204 615.726.0351 800.737.0351 615.259.4100 FAX serves: TN, AL</p>	<p>Delfield has 14 conveniently located Parts Depots to ensure parts are handled promptly and accurately.</p> <p>Delfield reserves the right to update or make changes to this list without prior notice</p> <p>Please call 1-800-733-8829 or check the web at www.delfield.com for a list of the current Parts Depots.</p>	



980 S. Isabella Rd., Mt. Pleasant, MI 48804-0470, U.S.A. • (989) 773-7981 or (800) 733-8821 • Fax (800) 669-0619 • www.delfield.com
Delfield reserves the right to make changes in design or specifications without prior notice. 2003 The Delfield Company. All rights reserved. Printed in the U.S.A.